

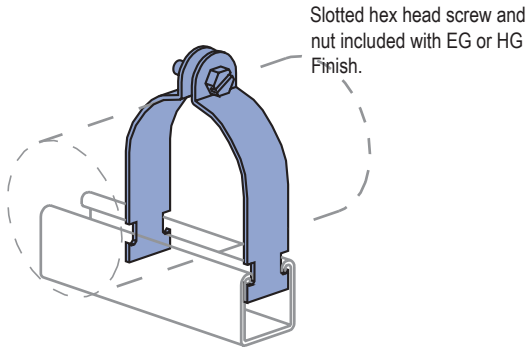

### P2024 THRU P2070-84

### PIPE CLAMPS FOR O.D. TUBING



**P2024 - P2029** 16 ga.  
**P2030 - P2035** 14 ga.  
**P2037 - P2052** 12 ga.  
**P2053 - P2066** 11 ga.  
**P2067 - P2070-84** 10 ga.

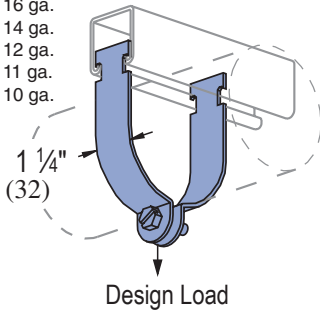

Part Number	O.D. Size In (mm)	Wt/100 pcs Lbs (kg)	Design Load Lbs (kN)
P2024	1/4 (6)	8 (3.6)	400 (1.78)
P2025	3/8 (10)	8 (3.6)	
P2026	1/2 (13)	9 (4.1)	
P2027	5/8 (16)	10 (4.5)	
P2028	3/4 (19)	11 (5.0)	
P2029	7/8 (22)	12 (5.4)	

Part Number	O.D. Size In (mm)	Wt/100 pcs Lbs (kg)	Design Load Lbs (kN)
P2030	1 (25)	14 (6.4)	600 (2.67)
P2031	1 1/8 (29)	15 (6.8)	
P2032	1 1/4 (32)	16 (7.3)	
P2033	1 3/8 (35)	17 (7.7)	
P2034	1 1/2 (38)	18 (8.2)	
P2035	1 5/8 (41)	19 (8.6)	
P1430	1 3/4 (45)	29 (13.2)	800 (3.56)
P2037	1 7/8 (48)	28 (12.7)	
P2038	2 (51)	31 (14.1)	
P2039	2 1/8 (54)	32 (14.5)	
P2040	2 1/4 (57)	33 (15)	
P1117	2 3/8 (60)	34 (15.4)	
P2042	2 1/2 (64)	35 (15.9)	
P2043	2 5/8 (67)	37 (16.8)	
P2044	2 3/4 (70)	38 (17.2)	
P1118	2 7/8 (73)	40 (18.1)	
P2046	3 (76)	41 (18.6)	1000 (4.45)
P2047	3 1/8 (79)	43 (19.5)	
P2048	3 1/4 (83)	45 (20.4)	
P2049	3 3/8 (86)	46 (20.9)	
P1119	3 1/2 (89)	47 (21.3)	
P2051	3 3/8 (92)	56 (25.4)	
P2052	3 3/4 (95)	58 (26.3)	
P2053	3 7/8 (98)	60 (27.2)	
P1120	4 (102)	62 (28.1)	
P2055	4 1/8 (105)	62 (28.1)	
P2056	4 1/4 (108)	64 (29.0)	1000 (4.45)
P2057	4 3/8 (111)	66 (29.9)	
P1121	4 1/2 (114)	67 (30.4)	
P2059	4 5/8 (118)	70 (31.8)	
P2060	4 3/4 (121)	72 (32.7)	

Part Number	O.D. Size In (mm)	Wt/100 pcs Lbs (kg)	Design Load Lbs (kN)
P2061	4 7/8 (124)	73 (33.1)	1000 (4.45)
P2062	5 (127)	74 (33.6)	
P2063	5 1/8 (130)	76 (34.5)	
P2064	5 1/4 (133)	77 (34.9)	
P2065	5 3/8 (137)	78 (35.4)	
P2066	5 1/2 (140)	79 (35.8)	
P2067	5 5/8 (143)	88 (39.9)	
P2068	5 3/4 (146)	90 (40.8)	
P2069	5 7/8 (149)	92 (41.7)	
P2070	6 (152)	94 (42.6)	
P2070-61	6 1/8 (156)	96 (43.5)	1000 (4.45)
P2070-62	6 1/4 (159)	98 (44.5)	
P2070-63	6 3/8 (162)	99 (44.9)	
P2070-64	6 1/2 (165)	100 (45.4)	
P1124	6 5/8 (168)	102 (46.3)	
P2070-66	6 3/4 (172)	104 (47.2)	
P2070-67	6 7/8 (175)	106 (48.1)	
P2070-70	7 (178)	108 (49.0)	
P2070-71	7 1/8 (181)	110 (49.9)	
P2070-72	7 1/4 (184)	112 (50.8)	
P2070-73	7 3/8 (187)	114 (51.7)	1000 (4.45)
P2070-74	7 1/2 (191)	116 (52.6)	
P2070-75	7 5/8 (194)	117 (53.1)	
P2070-76	7 3/4 (197)	119 (54.0)	
P2070-77	7 7/8 (200)	121 (54.9)	
P2070-80	8 (203)	123 (55.8)	
P2070-81	8 1/8 (206)	125 (56.7)	
P2070-82	8 1/4 (210)	126 (57.2)	
P2070-83	8 3/8 (213)	128 (58.1)	
P2070-84	8 1/2 (216)	129 (58.5)	
P1126	8 5/8 (219)	130 (59.0)	

### MATERIAL

Unistrut pipe clamps, unless noted, are punch-press made from hot-rolled, pickled and oiled steel plates, strip or coil, and conform to ASTM specifications A1008, A575, A576, A635, or A36. The fitting steel also meets the physical requirements of ASTM A1011 SS GR 33. The pickling of the steel produces a smooth surface free from scale.

Many items are also available in stainless steel.

Consult factory for ordering information.

### FINISHES

Pipe supports are available in:

- Electro-galvanized (EG), conforming to ASTM B633 Type III SC1
- Hot-dipped galvanized (HG), conforming to ASTM A123 or A153 (hardware)
- Perma-Green III (GR), and plain (PL).

<b>Project:</b> _____ <b>Architect / Engineer:</b> _____ <b>Date:</b> _____ <b>Phone:</b> _____ <b>Contractor:</b> _____ <b>Address:</b> _____ _____ <b>Notes 1:</b> _____ _____ <b>Notes 2:</b> _____ _____	<b>Approval Stamp:</b> _____ _____ _____
---	---